

# Bits and Bytes im Flow – Netzwerk im Wandel der Zeit

GUUG-Frühjahrsfachgespräch 2016

26. Februar 2016



Michel Rode  
Linux/Unix Consultant & Trainer  
B1 Systems GmbH  
rode@b1-systems.de

# Vorstellung B1 Systems

- gegründet 2004
- primär Linux/Open Source-Themen
- national & international tätig
- über 70 Mitarbeiter
- unabhängig von Soft- und Hardware-Herstellern
- Leistungsangebot:
  - Beratung & Consulting
  - Support
  - Entwicklung
  - Training
  - Betrieb
  - Lösungen
- dezentrale Strukturen

# Schwerpunkte

- Virtualisierung (XEN, KVM & RHEV)
- Systemmanagement (Spacewalk, Red Hat Satellite, SUSE Manager)
- Konfigurationsmanagement (Puppet & Chef)
- Monitoring (Nagios & Icinga)
- IaaS Cloud (OpenStack & SUSE Cloud & RDO)
- Hochverfügbarkeit (Pacemaker)
- Shared Storage (GPFS, OCFS2, DRBD & CEPH)
- Dateiaustausch (ownCloud)
- Paketierung (Open Build Service)
- Administratoren oder Entwickler zur Unterstützung des Teams vor Ort

# Software-defined networking – SDN

# Aufteilung

- Teil 1 - Allgemeiner Überblick
- Teil 2 - Umsetzung innerhalb von OpenStack
- Teil 3 - "Ausfallsichere" Kommunikation mit der Außenwelt

# Zuerst, warum SDN?

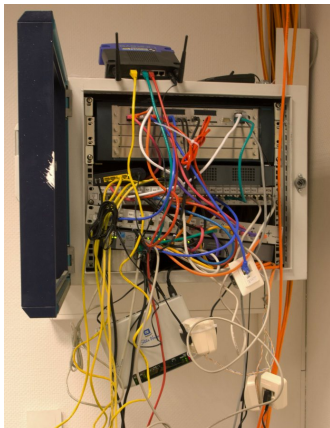

Quelle: <https://www.getdigital-blog.de/>

# Zuerst, warum SDN?

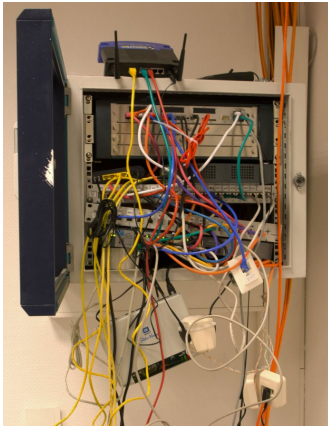

Quelle: <https://www.getdigital-blog.de/>

- zu komplex
- zu unflexibel
- ineffizient
- keine Automation

# Traditionell vs. modern

- Computing
  - Mainframe



# Traditionell vs. modern

- Computing
  - Mainframe
  - Server

# Traditionell vs. modern

- Computing
  - Mainframe
  - Server
  - KVM

# Traditionell vs. modern

- Provisioning
  - Diskette

# Traditionell vs. modern

- Provisioning
  - Diskette
  - CDROM

# Traditionell vs. modern

- Provisioning
  - Diskette
  - CDROM
  - qcow Image

# Traditionell vs. modern

- Networking
  - Kabel

# Traditionell vs. modern

- Networking
  - Kabel
  - ???

# Definition SDN

- Centralization
- Separation
- Automation & Orchestration



# Definition SDN

- Centralization
- **Separation**
- Automation & Orchestration

# Definition SDN

- Centralization
- Separation
- Automation & Orchestration

Ist das neu?

- Neu? Nein mit Perwoll gewaschen!

# Ist das neu?

- Wireless Controller
  - Cisco, Ubiquiti, ...

# Ist das neu?

- Wireless Controller
  - Cisco, Ubiquiti, ...
- Telco Hardware (zB MPLS)

# Ist das neu?

- Marionetten der IT

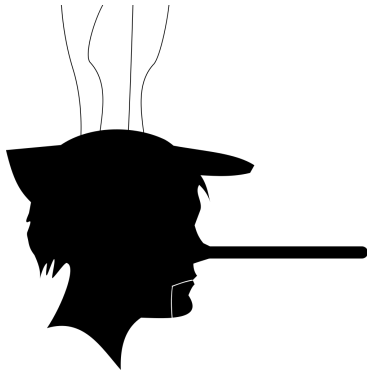

# Warum dann SDN?

# Logischer Aufbau

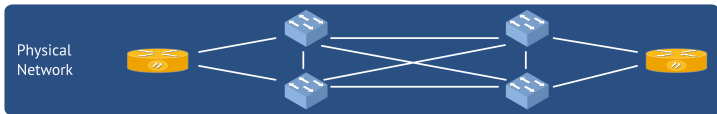



# Logischer Aufbau

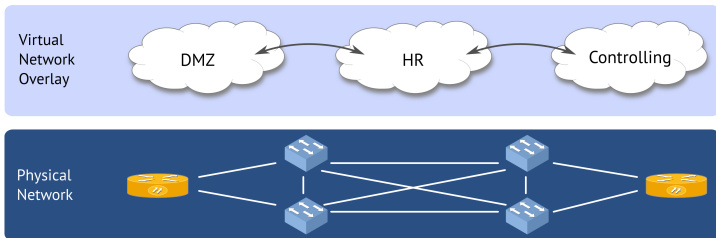

# Logischer Aufbau

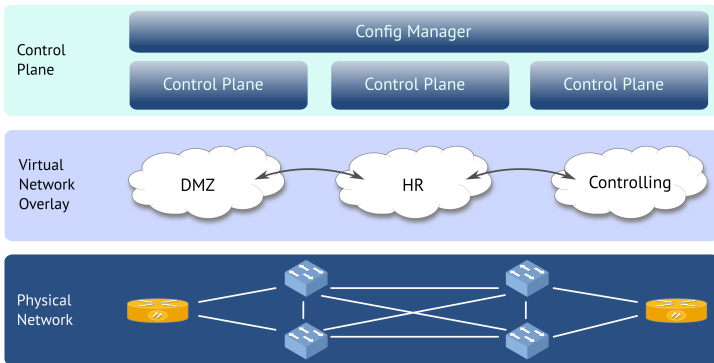

# Logischer Aufbau

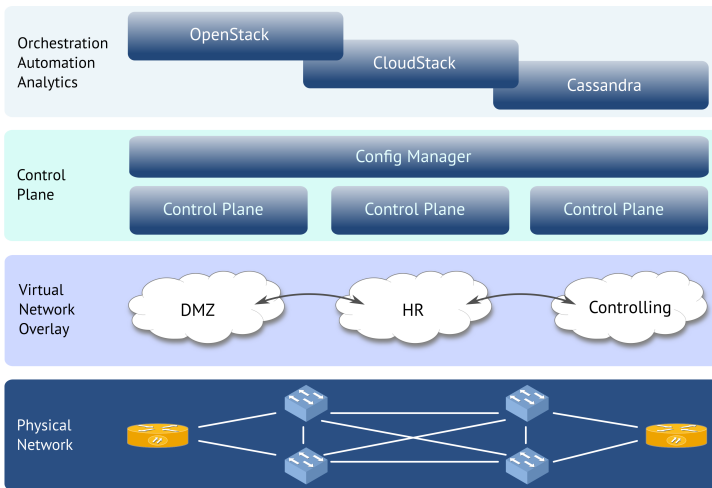

# Control Plane & Data Plane

- Trennung von
  - Logik und
  - Datenpfad
- Zentrale Verwaltung
- Dynamische Steuerung

# Control Plane & Data Plane

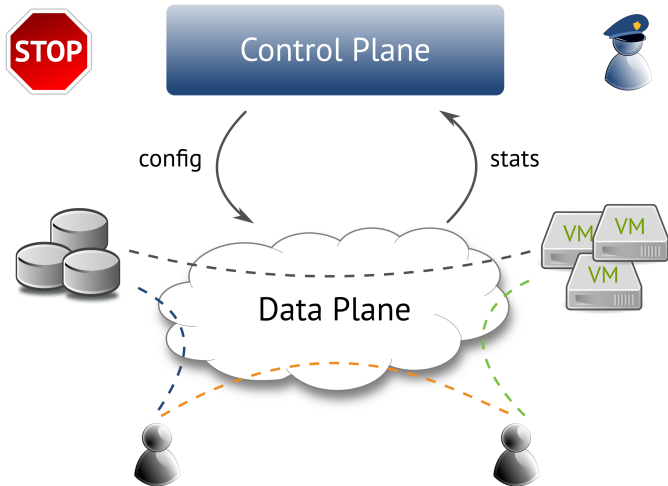



# Implementierung

# Implementierung

- Midonet
- Contrail/OpenContrail
- PLUMgrid
- OpenDayLight
- Floodlight
- Maestro
- ...

# Implementierung

- Midonet
- Contrail/OpenContrail
- PLUMgrid
- OpenDayLight
- Floodlight
- Maestro
- ...



# Implementierung

- Midonet
- Contrail/OpenContrail
- PLUMgrid
- OpenDayLight
- Floodlight
- Maestro
- ...

# Floodlight



Dashboard [Topology](#) Switches Hosts

10.0.0.1

## Network Topology

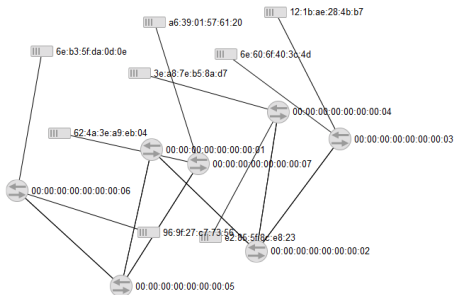

# OpenDayLight

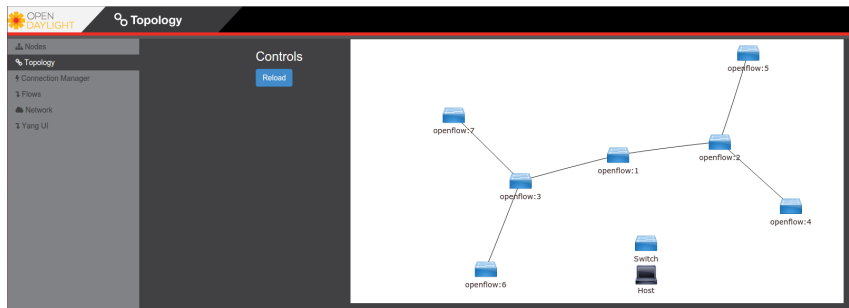

# OpenFlow & OpenStack

# Was ist (Open)Flow?

- vergleichbar mit einem L2 Switch
- erweitert um Header
- Schnittstelle - "API"
- Kombination aus Data- & Controlplane
- Flow als kleinste Einheit
- Routing-Protokoll für Netzwerkpakete

## Wo kommt das zum Einsatz?

- Neutron ML2 w/ openvswitch
  - Controller (Neutron)
  - Compute (Nova)
- Neutron ML2 w/ \*

# OpenvSwitch?

- Simple: Software-Switch
- Detail:
  - ovs-vs,of,dpctl
  - vswitchd & ovssdb
  - Verteile Installation mögl.
  - Unterstützt OpenFlow!!111

```

controller# ovs-ofctl dump-flows br-tunnel
NXST_FLOW reply (xid=0x4):
[...] table=0, n_bytes=0, idle_age=1395, priority=0 actions=drop
[...] table=0, n_bytes=1310, idle_age=1390, priority=1,in_port=1 actions=resubmit(,1)
[...] table=1, n_bytes=0, idle_age=1392, priority=2,dl_vlan=1,dl_dst=fa:16:3e:c9:10:fd actions=drop
[...] table=1, n_bytes=1268, idle_age=1390, priority=0 actions=resubmit(,2)
[...] table=1, n_bytes=0, idle_age=1392, priority=1,dl_vlan=1,dl_src=fa:16:3e:c9:10:fd \
[...] actions=mod_dl_src:fa:16:3f:1e:ba:3e,resubmit(,2)
[...] table=1, n_bytes=0, idle_age=1392, priority=3,arp,dl_vlan=1,arp_tpa=192.168.123.1 actions=drop
[...] table=2, n_bytes=378, idle_age=1390, priority=1,arp,dl_dst=ff:ff:ff:ff:ff:ff \
[...] actions=resubmit(,21)
[...] table=2, n_bytes=1160, idle_age=1392, priority=0,dl_dst=01:00:00:00:00:00/01:00:00:00:00:00 \
[...] actions=resubmit(,22)
[...] table=2, n_bytes=0, idle_age=1395, priority=0,dl_dst=00:00:00:00:00:00/01:00:00:00:00:00 \
[...] actions=resubmit(,20)
[...] table=3, n_bytes=0, idle_age=1395, priority=0 actions=drop
[...] table=3, n_bytes=0, idle_age=1392, priority=1,tun_id=0x1 actions=mod_vlan_vid:1,resubmit(,9)
[...] table=4, n_bytes=0, idle_age=1395, priority=0 actions=drop
[...] table=6, n_bytes=0, idle_age=1395, priority=0 actions=drop
[...] table=9, n_bytes=0, idle_age=1395, priority=0 actions=resubmit(,10)
[...] table=9, n_bytes=0, idle_age=1394, priority=1,dl_src=fa:16:3f:11:d2:65 actions=output:1
[...] table=10, n_bytes=0, idle_age=1395, priority=1 actions=learn(table=20,hard_timeout=300,\
[...] priority=1,cookie=0x99074aa5abe39b41,NXM_OF_VLAN_TCI[0..11],\
[...] NXM_OF_ETH_DST[]=NXM_OF_ETH_SRC[], \
[...] load:0->NXM_OF_VLAN_TCI[],load:NXM_NX_TUN_ID[]->NXM_NX_TUN_ID[],\
[...] output:NXM_OF_IN_PORT[]),output:1
[...] table=20, n_bytes=0, idle_age=1395, priority=0 actions=resubmit(,22)
[...] table=21, n_bytes=378, idle_age=1390, priority=0 actions=resubmit(,22)
[...] table=22, n_bytes=1448, idle_age=1390, priority=0 actions=drop

```



```
compute# ovs-ofctl dump-flows br-public
NXST_FLOW reply (xid=0x4):
[...] table=0, n_packets=698, n_bytes=59520, idle_age=1, priority=1 actions=resubmit(,3)
[...] table=0, n_packets=45, n_bytes=3868, idle_age=864, priority=0 actions=NORMAL
[...] table=0, n_packets=0, n_bytes=0, idle_age=863, priority=2,in_port=2 actions=resubmit(,1)
[...] table=1, n_packets=0, n_bytes=0, idle_age=863, priority=0 actions=resubmit(,2)
[...] table=2, n_packets=0, n_bytes=0, idle_age=863, priority=2,in_port=2 actions=drop
[...] table=3, n_packets=698, n_bytes=59520, idle_age=1, priority=1 actions=NORMAL
[...] table=3, n_packets=0, n_bytes=0, idle_age=863, priority=2,dl_src=fa:16:3f:1e:ba:3e \
[...] actions=output:2
```

```
controller# ovs-ofctl dump-flows br-public
NXST_FLOW reply (xid=0x4):
[...] table=0, n_packets=659, n_bytes=55965, idle_age=0, priority=1 actions=resubmit(,3)
[...] table=0, n_packets=49, n_bytes=4076, idle_age=824, priority=0 actions=NORMAL
[...] table=0, n_packets=0, n_bytes=0, idle_age=823, priority=2,in_port=2 actions=resubmit(,1)
[...] table=1, n_packets=0, n_bytes=0, idle_age=823, priority=0 actions=resubmit(,2)
[...] table=2, n_packets=0, n_bytes=0, idle_age=822, priority=2,in_port=2 actions=drop
[...] table=3, n_packets=659, n_bytes=55965, idle_age=0, priority=1 actions=NORMAL
[...] table=3, n_packets=0, n_bytes=0, idle_age=821, priority=2,dl_src=fa:16:3f:11:d2:65 \
[...] actions=output:2
```

# OpenFlow – Flows I

```
cookie=0x0, duration=2427.523s, table=2, n_packets=18, n_bytes=1719,  
idle_age=434, priority=2,in_port=2 actions=drop
```

- duration
- table
- packets/bytes
- idle\_age

## OpenFlow – Flows II

```
[..] idle_age=433, priority=2,dl_vlan=1,dl_dst=fa:16:3e:c1:64:05  
actions=strip_vlan,set_tunnel:0x1,output:2
```

- filter
  - priority
  - dl\_vlan
  - dl\_dst
  - nw\_src
  - nw\_proto
  - tp\_dst
- actions
  - strip\_vlan
  - set\_tunnel
  - output
  - resubmit

# Wer steuert das Ganze?

- Neutron Server
- L2-Agent/OpenvSwitch-Agent
- L3-Agent

# Wer steuert das Ganze?

- SDN-Controller
  - 'set-controller'
  - 'set-manager'
  - Plugins

# Hier entstehen Probleme...

## Service Layout

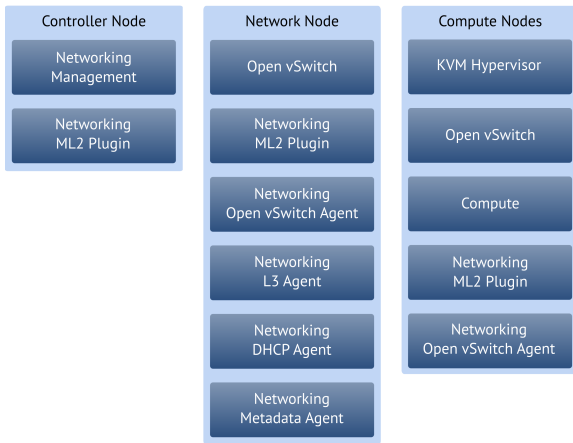

# Was tun?

- VRRP
- DVR
- neutron-ha-tool

# VRRP

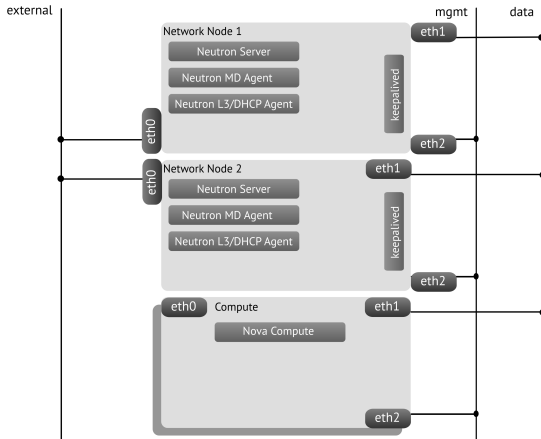



# VRRP

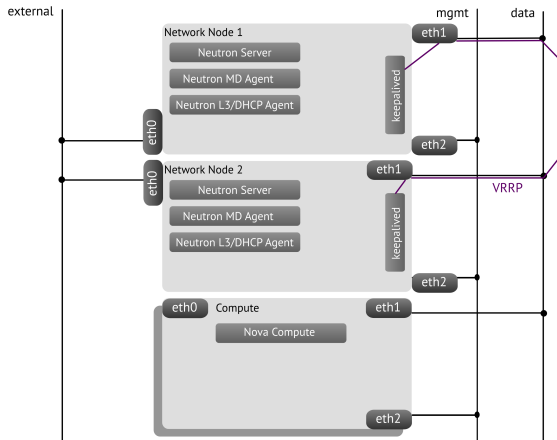

# VRRP

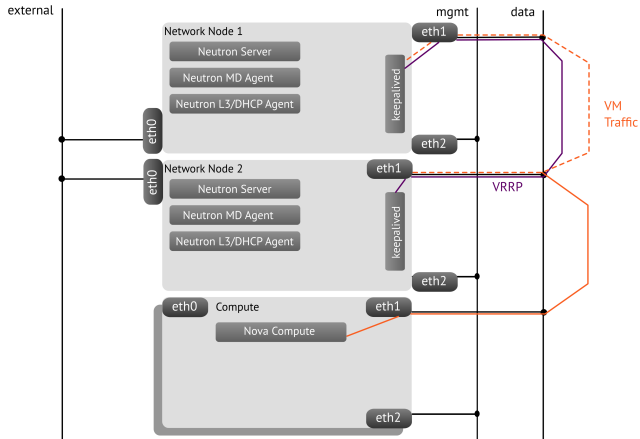

# VRRP

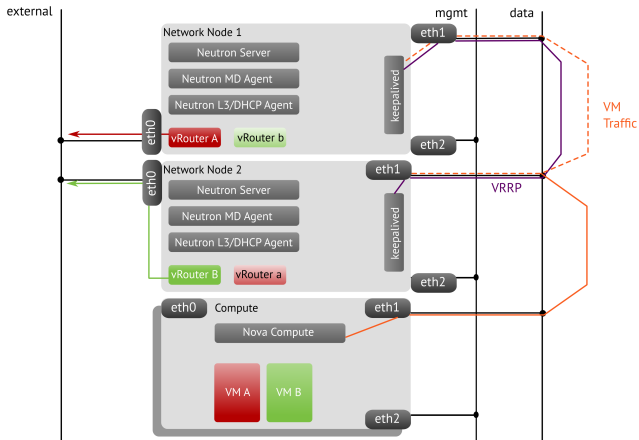

# VRRP - Eigenschaften

- keepalived
- contrackd
- ähnlich wie legacy
- Gedacht für "Ausfälle"

# DVR

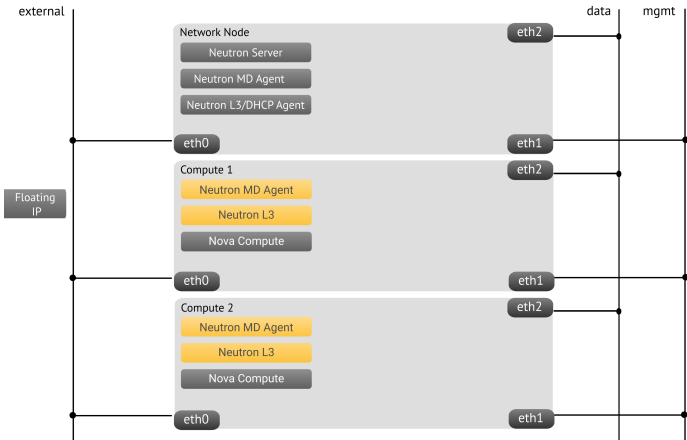

# DVR

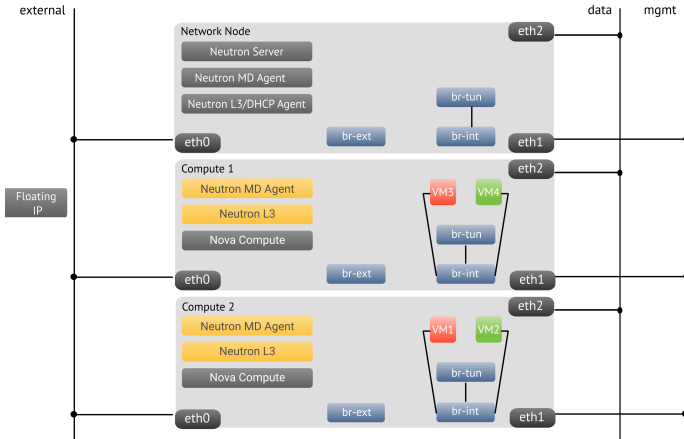

# DVR

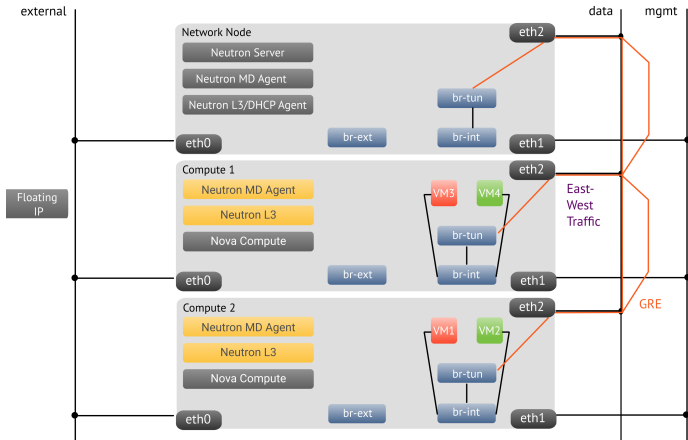

# DVR

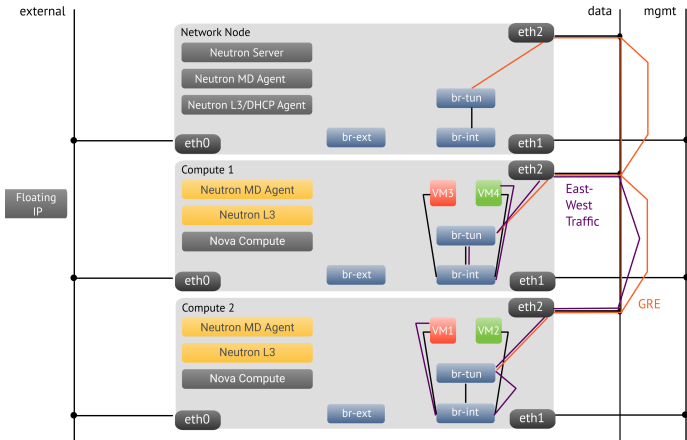



# DVR

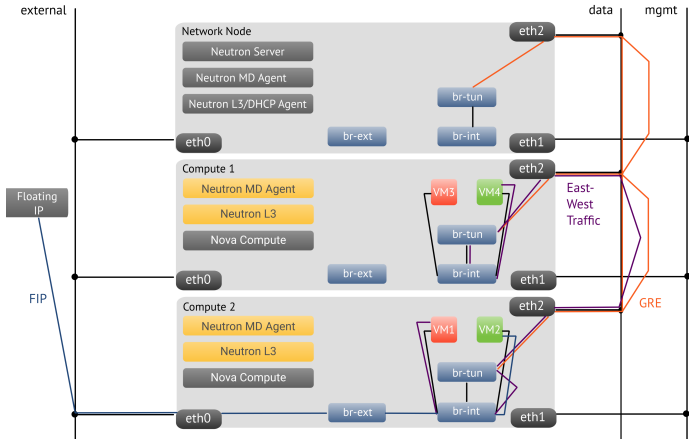

# DVR

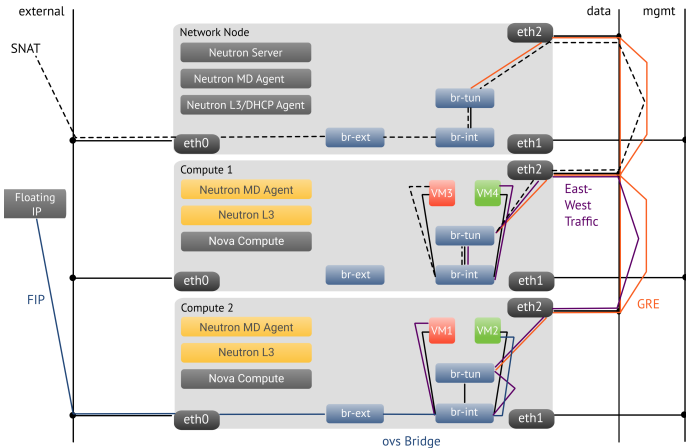

# DVR - Eigenschaften

- Computes brauchen "Public"-Netzwerk
- zusätzliche Namespaces
- Netzwerk-Performance
- Seit Juno

# neutron-ha-tool

- Pacemaker Installationen
- sichert L3 Agents ab
- Geringe Downtime

Vielen Dank für Ihre Aufmerksamkeit!

Bei weiteren Fragen wenden Sie sich bitte an [info@b1-systems.de](mailto:info@b1-systems.de)  
oder +49 (0)8457 - 931096